LMN3106ZF 30V N-Channel MOSFETs

Features

- 30V, 54A, $R_{DS(ON)} < 6m\Omega @ V_{GS} = 10V$
- High Power and current handing capability
- Lead Free and Green Devices Available
- DFN3x3-8L package design

Product Description

These N-Channel enhancement mode power field effect transistors are using trench DMOS technology. This advanced technology has been especially tailored to

minimize on-state resistance, provide superior switching performance, and withstand high energy pulse in the avalanche and commutation mode.

These devices are well suited for high efficiency fast switching applications.

Applications

- Portable Equipment
- Battery Powered System
- Net Working System

Pin Configuration

LMN3106ZF (DFN3x3-8L)	
PIN	Description
1	Source
2	Source
3	Source
4	Gate
5	Drain
6	Drain
7	Drain
8	Drain

Ordering Information

<u>LMN3106</u>	<u>Z</u>	<u>E</u>
LFC P/N	PKG code	Pb Free code

Marking Information

Part Number	Package	Quantity
LMN3106ZF	DFN3x3-8L	5000pcs

Absolute Maximum Ratings

 (T_C=25°C Unless otherwise noted)

Symbol	Parameter	Typical	Unit
V _{DS}	Drain-Source Voltage	30	V
V _{GS}	Gate-Source Voltage	±20	V
I _D	Continuous Drain Current	TC=25°C ¹	54
		TC=70°C	43
I _{DM}	Pulsed Drain Current ²	80	A
E _{AS}	Single Pulse Avalanche Energy ³	25	mJ
P _D	Power Dissipation	TC=25°C	26.6
		TC=70°C	17.1
T _J	Operating Junction Temperature	-55 to +150	°C
T _{STG}	Storage Temperature Range	-55 to +150	°C
R _{θJC}	Thermal Resistance-Junction to Case	4.7	°C/W

Note:

- 1.The maximum current rating is package limited.
- 2.Repetitive Rating: Pulse width limited by maximum junction temperature.
- 3.E_{AS} condition: T_J=25°C, V_{DS}=30V, V_{GS}=10V, R_G=25Ω, L=0.5mH, I_{peak}=24A.

Electrical Characteristics

 (T_C=25°C Unless otherwise noted)

Symbol	Parameter	Conditions	Min	Typ	Max	Unit
Static characteristics						
V _{(BR)DSS}	Drain-Source Breakdown Voltage	V _{GS} =0V, I _D =250uA	30			V
V _{GS(th)}	Gate Threshold Voltage	V _{DS} =V _{GS} , I _D =250uA	1.0		2.5	V
I _{GSS}	Gate Leakage Current	V _{DS} =0V, V _{GS} =±20V			±100	nA
I _{DSS}	Drain-Source Leakage Current	V _{DS} =30V, V _{GS} =0V			1	uA
V _{SD}	Diode Forward Voltage ³	V _{GS} =0V, I _S =2A			1	V
R _{DS(on)}	Drain-Source On-Resistance ³	V _{GS} =10V, I _D =20A		4.8	6	mΩ
		V _{GS} =4.5V, I _D =10A		6.9	9	
Gate charge characteristics						
Q _G	Total Gate Charge ^{3,4}	V _{DD} =15V, I _D =9A		16.7		nC
Q _{Gs}	Gate-Source Charge ^{3,4}			2.2		
Q _{Gd}	Gate-Drain Charge ^{3,4}			3.5		
Dynamic characteristics						
C _{iss}	Input Capacitance	V _{DS} =15V, V _{GS} =0V, f=1.0MHz		1155		pF
C _{oss}	Output Capacitance			456		
C _{rss}	Reverse Transfer Capacitance			72		
t _{d(on)}	Turn-On Time ^{2,3}	V _{DD} =15V, V _{GS} =10V, R _g =3Ω, I _D =9A		3.5		ns
t _r				5.5		
t _{d(off)}	Turn-Off Time ^{2,3}			13.5		
t _f				4.6		

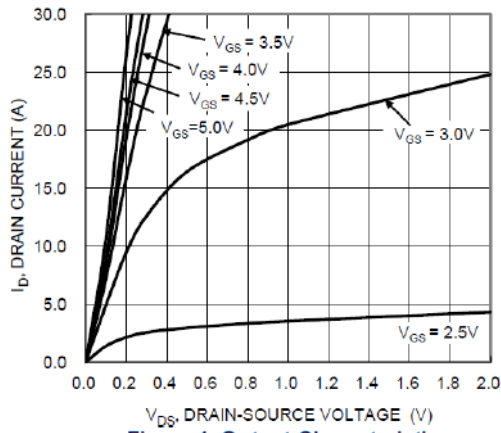
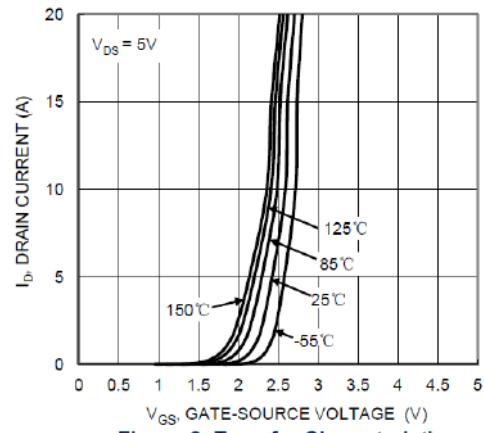
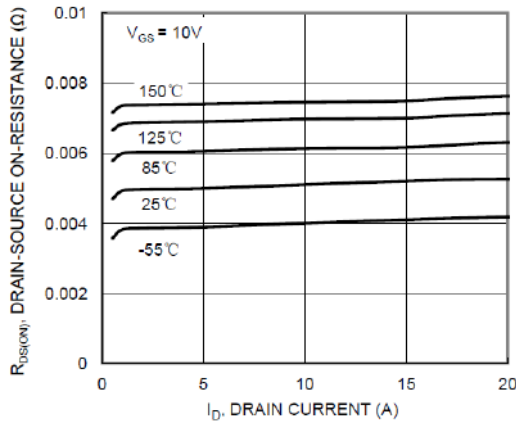
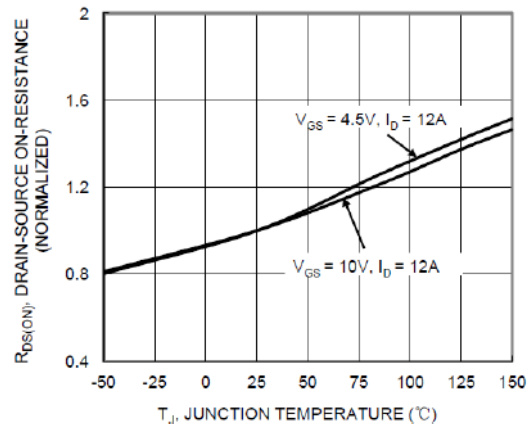
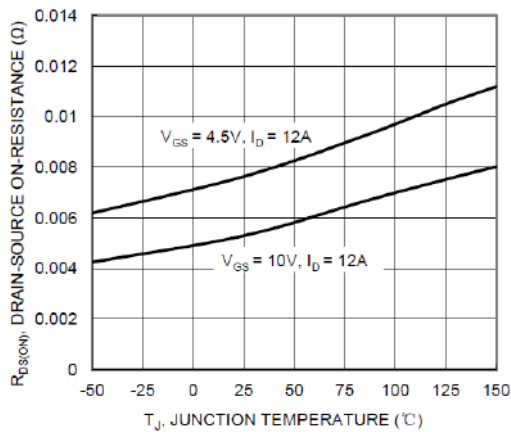
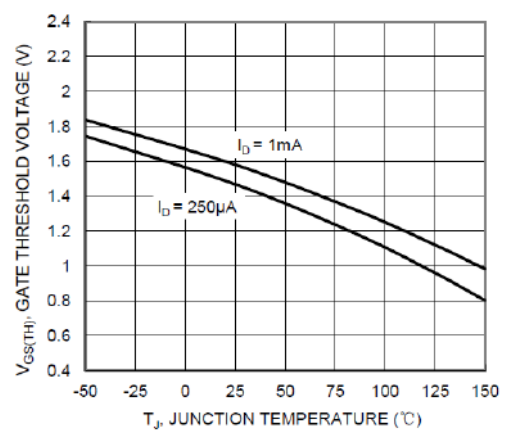
Typical Performance Characteristics

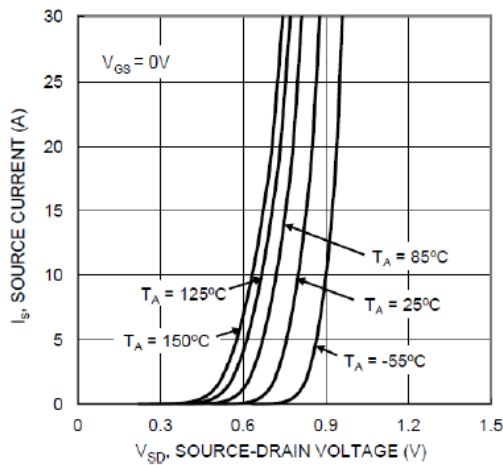
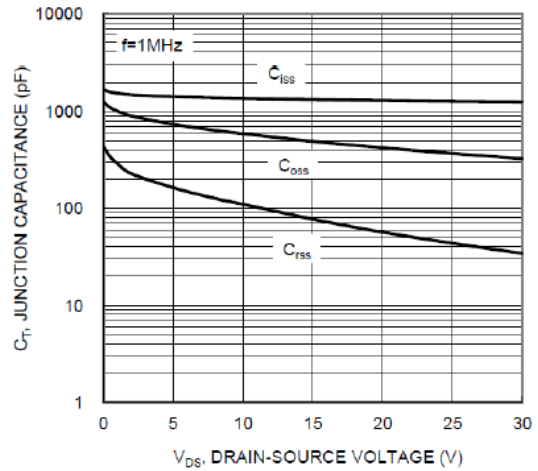
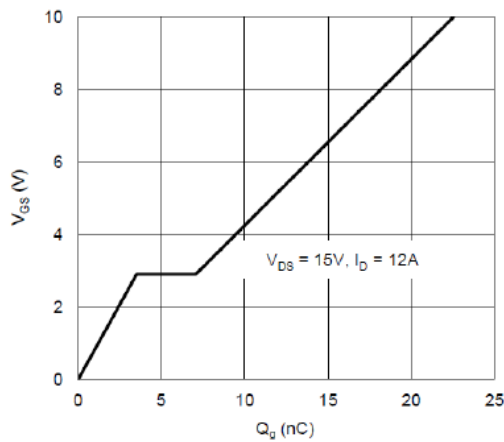
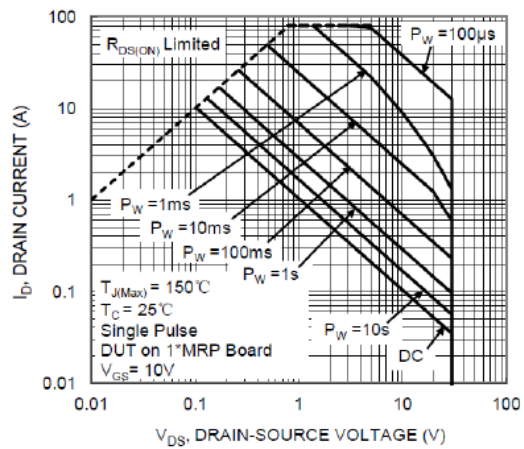
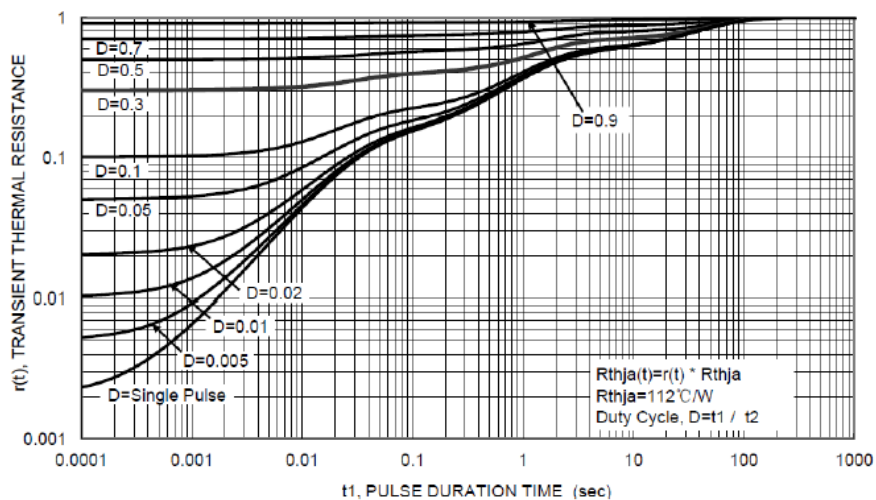
Figure 1. Output Characteristics

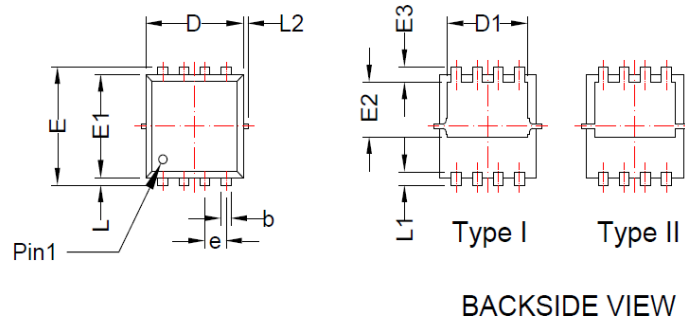
Figure 2. Transfer Characteristics

Figure 3. On-Resistance vs. Drain Current

Figure 4. Normalized $R_{DS(on)}$ vs. T_J

Figure 5. On-Resistance Variation with Temperature

Figure 6. Gate Threshold Variation vs. T_J

Figure 7. Diode Forward Voltage vs. Current

Figure 8. Capacitance

Figure 9. Gate Charge Waveform

Figure 10. Maximum Safe Operating Area

Figure 11. Normalized Transient Thermal Resistance

Package Dimension:
DFN3X3-8L

DIMENSION D AND E1 DOES NOT INCLUDE MOLD FLASH, PROTRUSIONS OR GATE BURRS. MOLD FLASH, PROTRUSIONS OR GATE BURRS SHALL NOT EXCEED 0.5mm PER INTERLEAD FLASH OR PROTRUSION SHALL NOT EXCEED 0.5mm PER SIDE.

Dimensions				
Symbol	Millimeters		Inches	
	Min	Max	Min	Max
A	0.700	0.900	0.028	0.035
A1	0.000	0.050	0.000	0.002
b	0.240	0.370	0.009	0.015
c	0.100	0.250	0.004	0.010
D	2.900	3.250	0.114	0.128
D1	2.350	2.600	0.093	0.102
E	3.050	3.450	0.120	0.136
E1	2.900	3.200	0.114	0.126
E2	1.350	2.000	0.053	0.079
E3	0.300	0.600	0.012	0.024
e	0.650 BSC		0.026 BSC	
L	0.020	0.200	0.001	0.008
L1	0.280	0.500	0.011	0.020
L2	---	0.150	---	0.006

NOTICE:

LFC Semiconductor assumes no responsibility for equipment failures that result from using products at values that exceed, even momentarily, rated values (such as maximum ratings, operating condition ranges, or other parameters) listed in products specifications of any and all LFC Semiconductor products described or contained herein. LFC Semiconductor products are not designed for use in life support appliances, devices or systems where malfunction of these products can be reasonably expected to result in personal injury. Reproduction in whole or in part is prohibited without the prior written consent of the copyright owner.

Applications shown on the herein document are examples of standard use and operation. Customers are responsible in comprehending the suitable use in particular applications. LFC Semiconductor makes no representation or warranty that such applications will be suitable for the specified use without further testing or modification.

Information furnished is believed to be accurate and reliable. However LFC Semiconductor assumes no responsibility for the consequences of use of such information nor for any infringement of patents or other rights of third parties, which may result from its use. No license is granted by implication or otherwise under any patent or patent rights of LFC Semiconductor. Specifications mentioned in this publication are subject to change without notice. This publication supersedes and replaces all information without express written approval of LFC Semiconductor.